

Les Paul / Gibson Style Guitar

2 Volume Controls - 2 Tone Controls - 3-Way Switch

Note : In the Middle Pickup Position either volumes acts as master volume

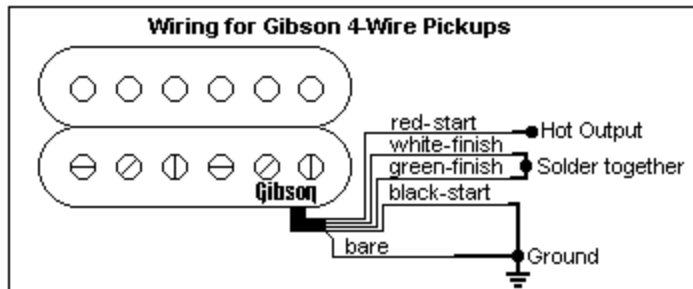

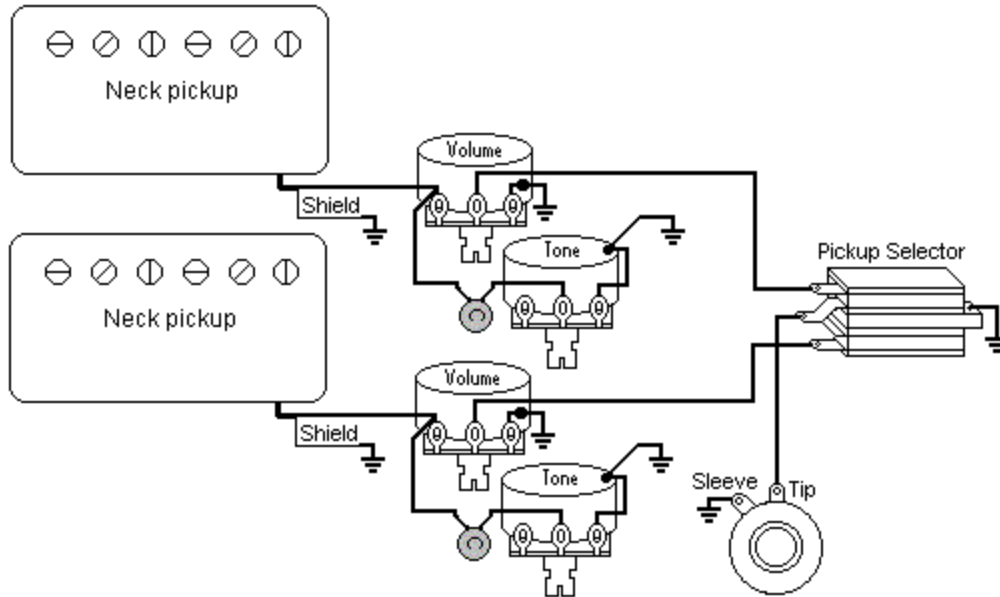

Les Paul / Gibson Style Guitar

2 Volume Controls - 2 Tone Controls - 3-Way Switch

Note: In the Pickup Switch middle position, each volume works independently

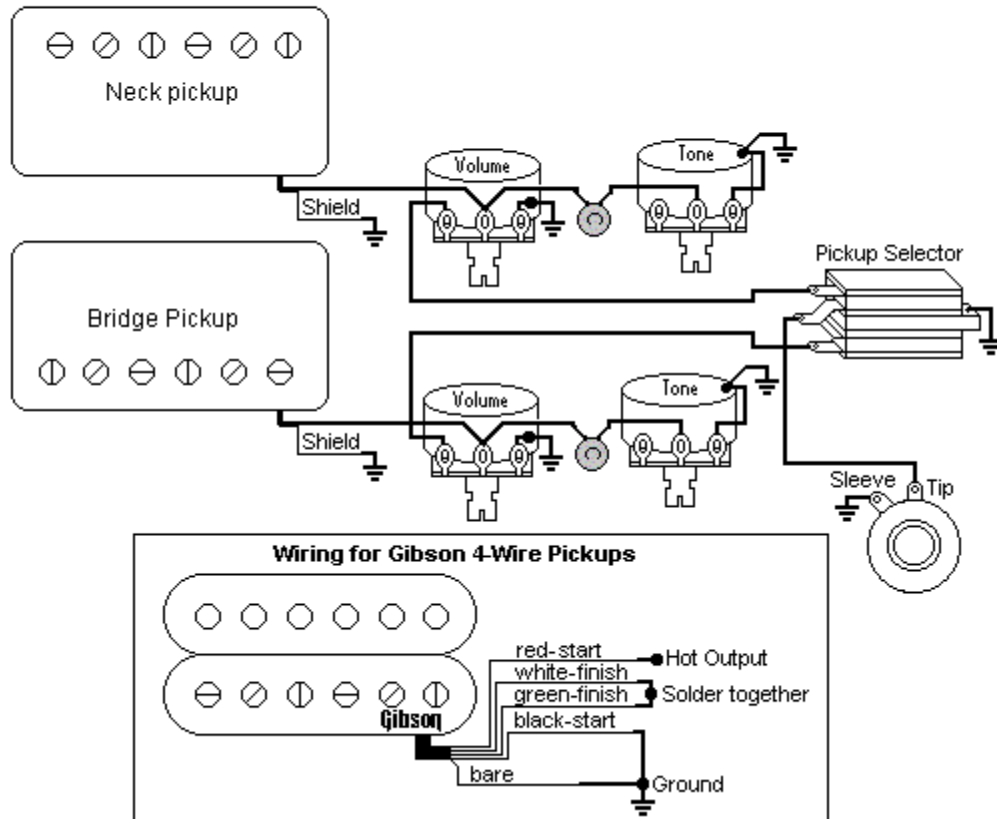

Strat Style Guitar

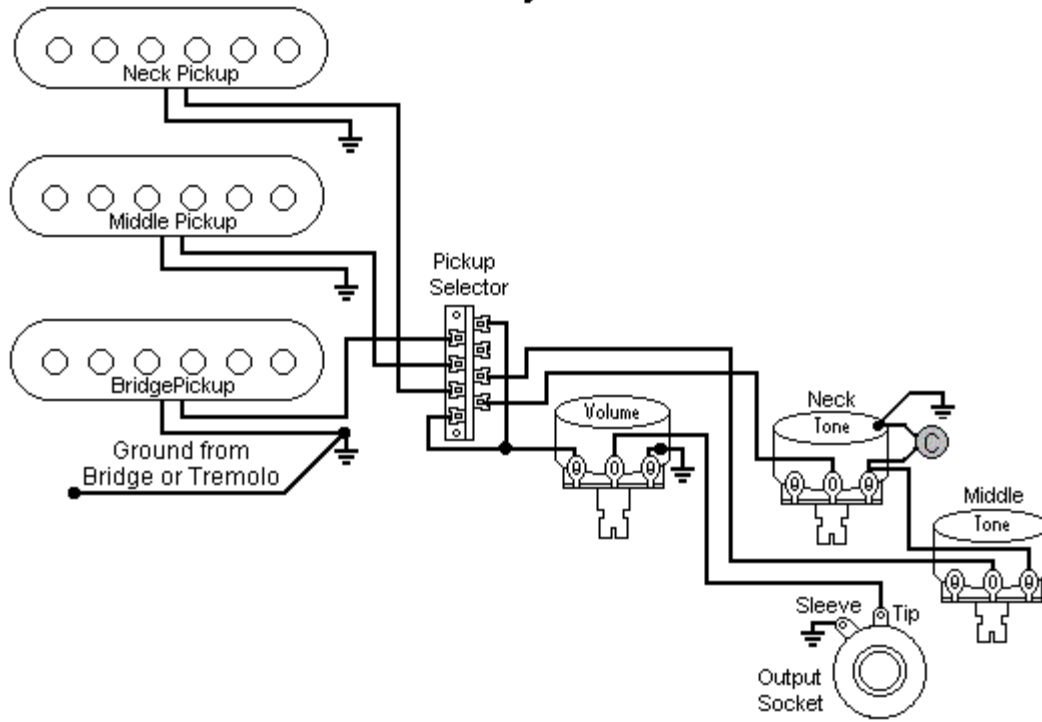

Tele Style Guitar

